



2015 Van Terra XLT—13 Pass w/ Luggage

Interior: Black Vinyl

Exterior Color : White

Seats: Amarillo Black



Ford E350 5.4 Ltr V8 Gas Engine 12,500 GVW

STANDARD OPTIONS:

EXTERIOR:

- ☞ Welded tubular steel cage w/ seat track in floor & sidewalls
- ☞ Welded perimeter steel floor frame supported by reinforced box style crossmembers
- ☞ Re-Routed exhaust to driver's side
- ☞ Steel wheels well pans
- ☞ Drive shaft guard
- ☞ Rear mud flaps
- ☞ Steel cage primed with rust inhibitor
- ☞ Underbody foam sealed and undercoated
- ☞ 5/8" AdvanTech Subfloor
- ☞ One-Piece pre-molded fiberglass aerodynamic top
- ☞ Fiberglass rear cowl & Fiberglass composite exterior sidewalls
- ☞ Contoured fiberglass lower body skirts and running boards
- ☞ Steel reinforced fiberglass rear bumper
- ☞ 1" polystyrene foam board insulation
- ☞ (5) Tinted solid windows (28.5" w x 34.5" h)
- ☞ (2) Tinted solid side egress windows (28.5" w x 35.5" h)
- ☞ Tinted solid rear egress windows (54" w x 26" h)
- ☞ Entrance door - 29" Electric bi-fold with tinted glass (in body door)
- ☞ LED stop/tail/turn lights
- ☞ Red Reflectors (2 side, 2 rear)
- ☞ LED running and clearance lights (9 red and 7 amber)
- ☞ Incandescent backup and license plate lights
- ☞ LED High mount centered rear brake light
- ☞ Velvac manual exterior mirrors (L & R)
- ☞ 3" Convex spot mirrors (L & R)
- ☞ Overall white paint
- ☞ White steel wheels
- ☞ Nitrogen tire inflation
- ☞ Front end alignment check

INTERIOR:

- ☞ OEM dual high back driver captains chairs
- ☞ OEM front door panels with map pockets and door pulls
- ☞ OEM rubber floor mat in cab
- ☞ OEM AM/FM/CD stereo radio with 2 speakers in cab
- ☞ OEM dash A/C & heat standard
- ☞ OEM interior rear view mirror
- ☞ Black Carpeted Floor, with smooth black rubber in stepwell & black rubber step treads
- ☞ Black Carpeted sidewalls to seat rails
- ☞ ABS Wheel well covers
- ☞ Vinyl-covered ceiling and sidewalls
- ☞ Vinyl-covered front and rear bulkheads: (front bulkhead doors with vinyl inserts)
- ☞ Small storage compartment in front bulkhead
- ☞ Modesty Panel & angled hand rail at left of entrance door, grab bar (18") at right of entrance door
- ☞ Operator-friendly lighted switch panel
- ☞ State of the art electrical panel with printed circuitry
- ☞ Color-coded high temp GXL wiring with positive-lock, weatherproof connectors
- ☞ Convenience lighting in cab and stepwell
- ☞ Incandescent dome lighting in ceiling
- ☞ 72" Lap Belts

Dimensions:

Wheel Base	158"
Floor Length	176"
Overall Length	23'
Exterior Height	109"
Exterior Length	96"
Interior Height	75"
Interior Width	79"
Door Width	30"
Ground to 1st step	10.5"

ABOVE STANDARD OPTIONS:

- ☞ Air Conditioning—60,000 BTU
- ☞ Heater—65,000 BTU
- ☞ Auxiliary Heater Performance Pkg
- ☞ Elite Bonded Window Pkg
- ☞ Luggage Compartment w/ Single Deluxe Door
- ☞ Kubota Key Switch
- ☞ Frame mounted Battery slides
- ☞ Speaker Pkg
- ☞ PA System
- ☞ RVS Backup Camera w/ 7" Mirror Monitor (includes: 7" windshield mount LCD monitor, Blind Spot Assist System, (2) side view blind spot cameras, (1) rear backup RGB camera)
- ☞ (7) 12V USB Charging Ports
- ☞ Altro Flooring, Storm Gray
- ☞ Engine Console Convenience Center
- ☞ Remote Heated Power Mirrors
- ☞ Stainless Steel Wheel Liners
- ☞ Driver Safety Shield Modesty Panel
- ☞ High-Gloss Walnut Wood Pkg
- ☞ LED Interior Dome Light Pkg
- ☞ (2) Double High Back Rigid Seats w/ Pillow headrest, seat belt loops, 72" retractable seat belts and arm rests
- ☞ (3) Double High Back Recliner Seats w/ Pillow headrest, seat belt loops, 72" retractable seat belts and arm rests
- ☞ (2) Single High Back Recliner Seats w/ Pillow headrest, seat belt loops, 72" retractable seat belts and arm rests
- ☞ Gray/Silver Vinyl Graphics
- ☞ Painted Skirts—Silver
- ☞ **Turtle Top Extended Body Warranty 5 Years / 100,000 Miles**

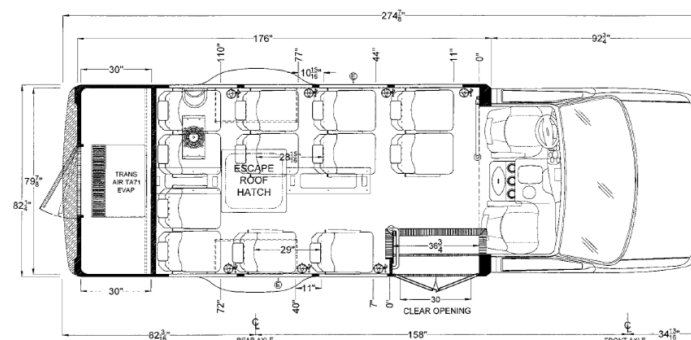

4 Years/50,000 Mile Workmanship

5 Years/100,000 Mile Structural



For pricing call
(800) 662-2435

Stock #
65005N-15 & 65006N-15

